



## 3100LA

# Broadband Power Amplifier



HIGH RF VOLTAGES MAY BE PRESENT AT THE OUTPUT OF THIS UNIT. All operating personnel should use extreme caution in handling these voltages and be thoroughly familiar with this manual.

Do not attempt to operate this unit prior to reading this manual.

## Warranty

Electronics & Innovation Ltd., (hereafter E&I) warrants for the period of three years from the date of original delivery, each unit to be free of defects in materials and workmanship. For the period of 36 months E&I will, at its option, repair or replace defective parts so as to render the unit fully operational such that it performs according to the original specifications; free of charge to the original purchaser.

Should warranty service be required, the unit must be returned to E&I, freight cost to be borne by the owner. If, in our opinion, the unit has been damaged by use outside the limits prescribed in this manual or by accident, then the warranty shall not be honored. In such a case E&I will provide an estimate for repair, assuming repair is possible and provide a quote at standard service rates.

## Contents

Chapter 1	
General Information.....	3
Chapter 2	
Operation.....	4
Chapter 3	
Technical Information.....	7
Chapter 4	
Maintenance.....	8
Chapter 5	
Safety.....	12

The material contained in this document is the property of Electronics & Innovation Ltd., it is subject to change without notice.

---

## **Chapter 1 Introduction**

The 3100LA is a broadband solid state amplifier covering the frequency spectrum from 250 KHz to 150 MHz. It is rated at 100 watts of RF power with low harmonic and intermodulation distortion. 150 watts of saturated power can be produced with increased distortion products. A highly linear Class A design, the 3100LA will amplify inputs of AM, FM, SSB, pulse and any complex modulation signals. The amplifier has 50 dB gain, it is unconditionally stable and will not oscillate even with combinations of mismatched source and load impedance. It is protected against failure due to output load mismatch and/or overdrive.

RMS forward and reverse powers are monitored by a front panel meter. An integral power supply permits operation from 115/230 single phase AC power.

### **1.2 INSTRUMENTATION IDENTIFICATION**

Each amplifier is identified by a serial number tag on the back panel of the unit. Both the model number and the serial number should be quoted to identify specific unit.

### **1.3 SPECIFICATIONS**

Physical and electrical specifications are listed in Table 1-1 below

The material contained in this document is the property of Electronics & Innovation Ltd., it is subject to change without notice.

**Table 1-1. SPECIFICATIONS**

FREQUENCY COVERAGE:	250 kHz to 150 MHz.
GAIN:	50 dB min, $\pm 1.5$ variation.
CLASS A LINEAR OUTPUT:	Nominal 100 watts.
HARMONIC DISTORTION:	> -25 dBc at 100 watts output.
SATURATED RF POWER OUTPUT:	150W Min.
INPUT IMPEDANCE	50 ohms, VSWR, 1.5:1 Maximum.
OUTPUT IMPEDANCE:	50 ohms, VSWR, 2.5:1 Maximum
STABILITY:	Continuous operation into any load or source impedance.
PROTECTION:	Unit will withstand a + 13dBm input signal (1.0 Volts RMS).
POWER OUTPUT METER:	True RMS power detection. $\pm 3\%$ of full scale accuracy.
POWER REQUIREMENTS:	100 – 240 VAC 47-63 Hz.
SIZE:	5.3" x 16.5" x 18.4" 134.5 mm x 420 mm x 467 mm
WEIGHT:	52 pounds 23.6 kg
CONNECTORS:	N
OPERATING TEMPERATURE:	0 – 40 C
RACK MOUNTING:	Optional Rack Mount Ears

---

## **Chapter 2 Operation**

### **2.1 INTRODUCTION**

The 3100LA RF amplifier is used to amplify the RF level of signal sources in the 250 KHz to 150 MHz range. No tuning or any other form of adjustment is required.

The 3100LA produces rated power output at its output connector, regardless of load impedance. Any power reflected due to output load mismatch is absorbed in the amplifier. Therefore, although the output impedance is 50 ohms (maximum VSWR: 2.5:1), the amplifier will work into any load impedance.

### **2.2 RACK INSTALLATION**

This unit is 5U high, 17" width. With the handles removed it will fit into a standard rack.

The material contained in this document is the property of Electronics & Innovation Ltd., it is subject to change without notice.

## 2.2.1 Mains Voltage

The unit accommodates AC line voltages from 100 TO 240 VAC 47 – 63 Hz

## 2.3 OPERATION

A line cord is supplied to form a connection between the mains supply and the rear of the unit. Plug this into the AC input at the rear of the unit and the AC mains outlet.

### 2.3.1 Proceed as follows:

- (i) Ensure that there is at least 3” or 7.5 cm clearance at the rear of the unit for air flow.
- (ii) Ensure RF input voltage is not excessive
  - a. The 1 V rms indicated maximum input voltage is 5 times the level of the input signal required to achieve maximum output. Input voltages in excess of 2 volts peak may permanently damage the instrument.
- (iii) Connect the output via a 50 ohm coaxial lead and N plug to the load.
- (iv) Connect the input signal via a 50 ohm coaxial lead and N plug to the input connector.

### 2.3.2 Front Panel Display

The 3100LA front panel has a passive LCD display designed for simplicity and ease of use. During initialization, the LCD shows the software revision. After the amplifier is initialized, the LCD indicates Forward Power, Reflected Power, and amplifier status (see figure 2.1).

Pf: \_\_\_ W Pr: \_\_\_ W  
Status: \_\_\_\_\_

*Figure 2.1 : Front Panel Display*

Where Pf refers to forward power, Pr refers to reverse power, and Status indicates “OK” unless there is a fault condition, such as:

- Overheat (heat-sink temperature is too high for reliable operation)
- PSU fault (internal fault in the main switching power supply)

In the event of a fault, the unit may be reset by cycling the power. In the case over an over temp fault, ensure that the air inlet and out let are not restricted. If the fault persists, please contact Service Department.

The material contained in this document is the property of Electronics & Innovation Ltd., it is subject to change without notice.

### 2.3.3 RS 232 Interface

The 3100LA features a standard RS-232 serial interface suitable for connection to a PC or host system. The communication protocol is extremely simple to facilitate readback and control with readily available terminal programs such as Hyperterm. The RS-232 link has the following parameters:

Baud rate: 19200

Data bits: 8

Parity: none

Stop bits: 1

Flow control: none

An example configuration using HyperTerminal on a PC is shown in figure 2.2.

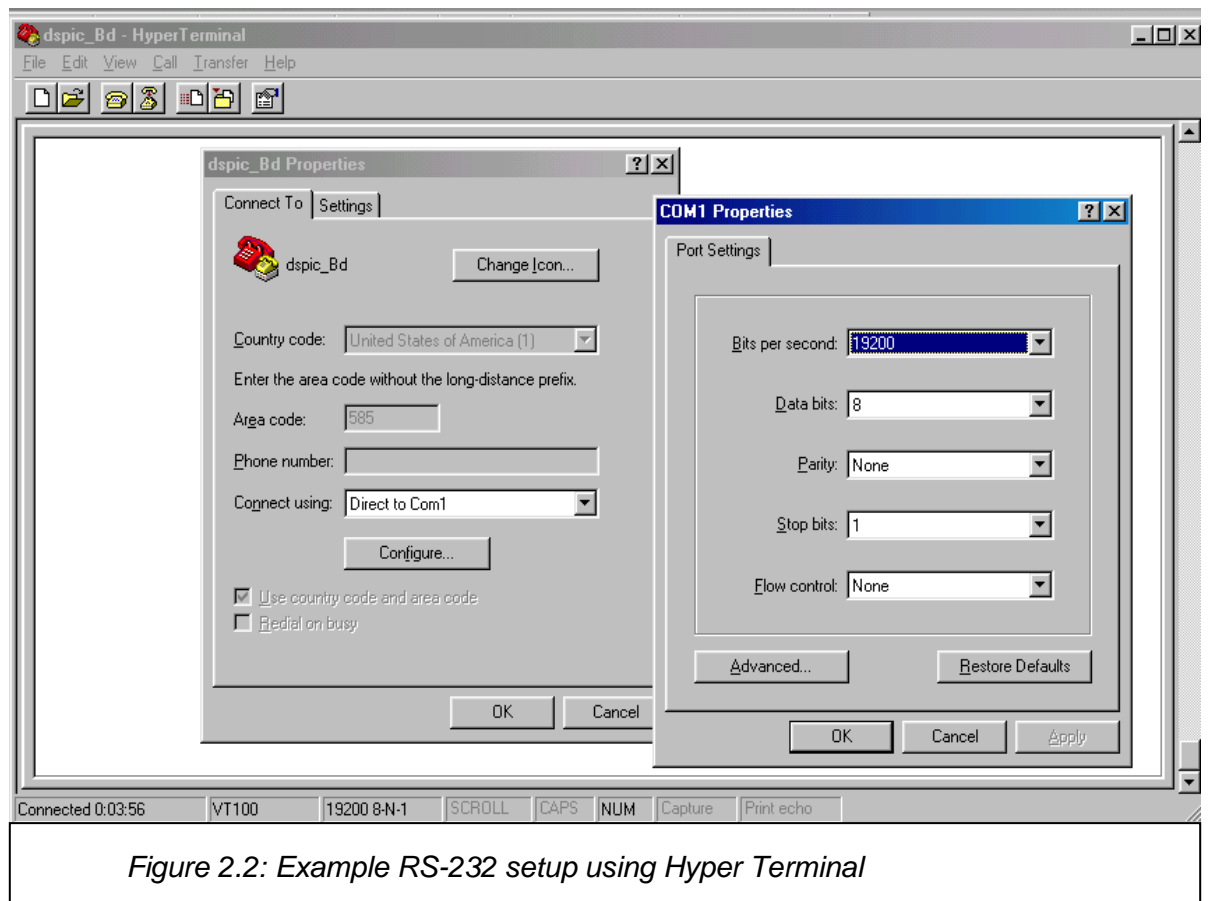

In the default state, the RS-232 port will echo the same information sent to the front panel LCD display, allowing a running datalog to be stored to disk using the capture feature of the terminal program.

Single character commands can be sent to the amplifier to achieve the following:

The material contained in this document is the property of Electronics & Innovation Ltd., it is subject to change without notice.

"1" key enables telemetry (readback similar to LCD display) - this is the default mode at power up

Custom commands and display lists can be implemented upon customer request.

---

## **Chapter 3 Technical Description**

### **3.1 GENERAL DESCRIPTION**

The 3100LA is designed to amplify signals by 50 dB in the frequency band of 250 KHz to 150 MHz. The signal from the front panel N connector is fed via a length of 50 ohm coaxial cable into the input of the driver amplifier module. The signal from the input of the driver is coupled to the input of the MMIC front end. The output signal of the MMIC is coupled to the gate of transistor Q1. The further amplified signal appearing at the drain of Q1 is coupled to the input of Q2. This is transformed to 50  $\Omega$  and fed to the driver output N port.

The driver output signal is fed through a length of coaxial cable to the input of the splitter network. The two output signals are fed to the two power amplifiers. Each amplifier has a four way splitter the outputs of which are fed to the individual PA PCBs each containing an RF MosFet that is in a push-pull configuration. The output of these are then fed to the combining network of the PA module.

The power amplifier module output is fed to the RF bi-directional coupler. The output of the coupler is then fed directly to the N connector on the front panel, this is the unit output.

The forward and reverse coupled ports of the bi-directional coupler are fed to the RF detector which is situated on the main control board. The RF detector feeds a voltage, which is representative of the true RMS power to the control board proper. The control board in turn drives the front panel display.

The main power supply unit provides a 24 VDC 12 ampere source. It is a switch mode power supply unit. The output feeds the PA and the drive amplifier. The main power supply also has a 5 VDC output which feeds the control board.

The material contained in this document is the property of Electronics & Innovation Ltd., it is subject to change without notice.

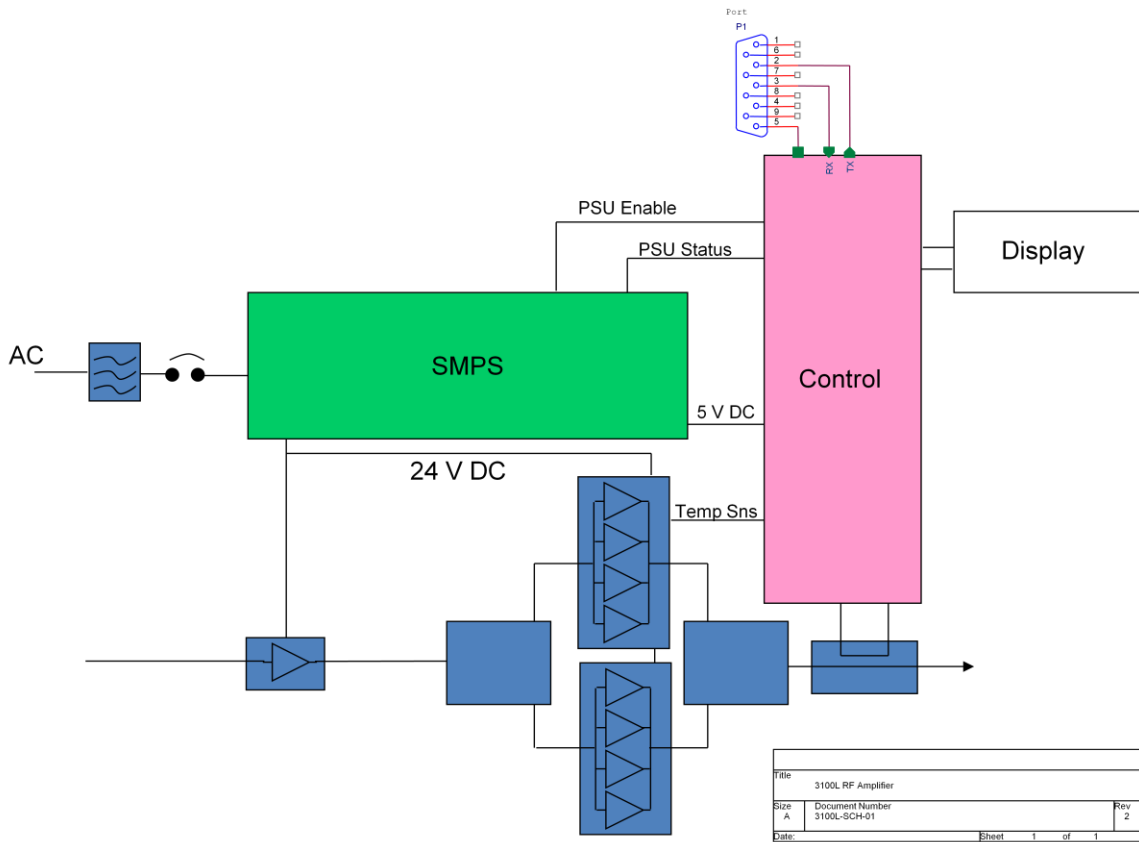

## **Chapter 4 Maintenance**

### 4.1 INTRODUCTION

The E&I 3100LA RF amplifier requires no periodic maintenance. The instrument is unconditionally stable and is fail-safe under all load conditions. Damage can only be externally caused by the incorrect selection of the AC supply voltage or by an input signal in excess of the specified 1 volt rms equivalent to a power level of 13dBm.

This chapter therefore, deals only with certain fundamental procedures for fault location.

Performance limits quoted are for guidance only and should not be taken for guaranteed performance specifications unless they are also quoted in the Specification Section 1.2.

### 4.2 PERFORMANCE CHECKS

To determine the amplifier's performance carry out the following procedure. The material contained in this document is the property of Electronics & Innovation Ltd., it is subject to change without notice.



#### 4.2.1 Initial Check

The following check can be made after repair and adjustments or whenever the condition of the unit is in question.

- a. Connect AC power supply. Switch on power and observe that the display initializes.
  - b. Connect a sweep generator (HP 8601 or similar) capable of sweeping the frequency range 250 KHz to 150 MHz, to the input connector.
  - c. Adjust the output level of the sweep generator so that a 50 ohm video detector connected at the output of the unit will not be damaged by excessive power output. (Reference section 4.4.1 for set up.)
  - d. Observe the gain versus frequency ripple on an oscilloscope calibrated in decibels. The gain variation must be not more than +/- 1.5 dB over the frequency range.
  - e. Connect a calorimetric power meter (HP434 or equivalent) through a 10 dB 200 watt attenuator to the output connector. Adjust the input CW signal to any frequency between 250 kHz and 150 MHz for 100 watts output.
  - f. Observe the harmonic distortion of the output on a spectrum analyzer. The harmonic components contributed by the amplifier should be better than 25 dB down from the fundamental.
- (a) If the above items are found to be outside of the specification, check the spectral content of the input signal. If this is a pure signal then the unit needs to be returned to the factory for service.

#### 4.3.1 Measurement of Gain

##### 1. Equipment Required (or equivalent):

- a) Oscilloscope - Tektronix T921
- b) Sweep/Generator - HP8601A
- c) Signal Generator - Exact Model 7060

The material contained in this document is the property of Electronics & Innovation Ltd., it is subject to change without notice.

- d) 50 ohm Detector - Wavetek D151
- e) Attenuator, 30 dB, 200 Watts Bird

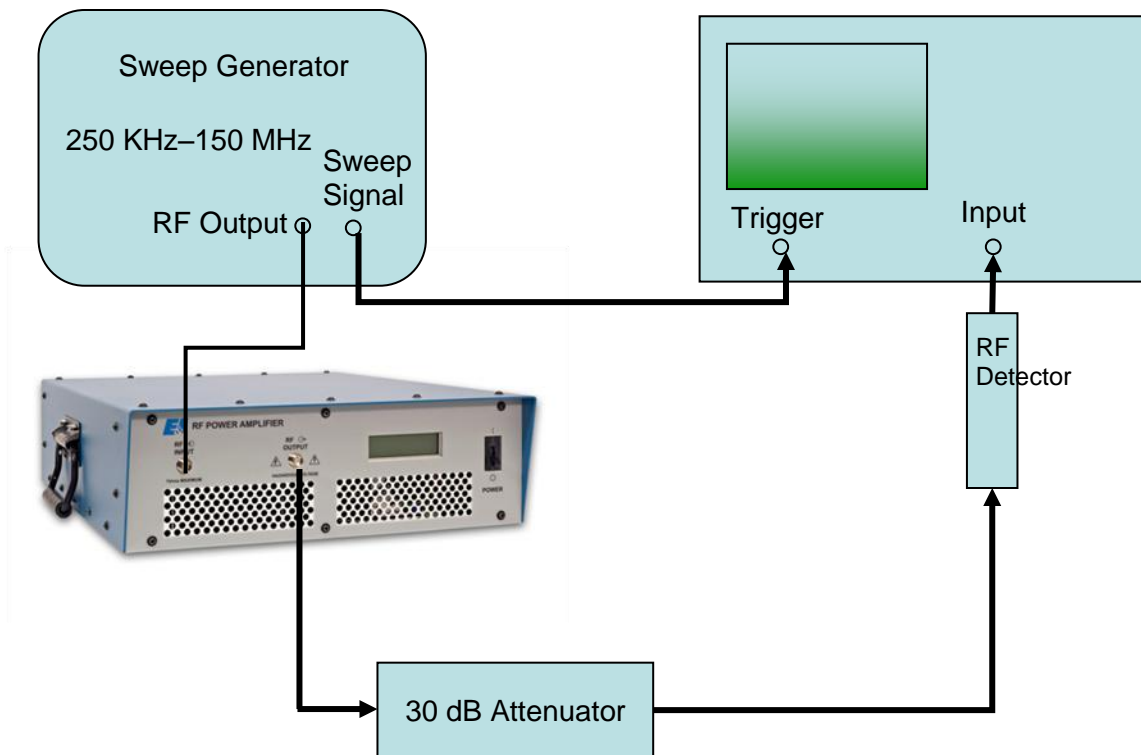

Figure 4-1. Gain Measurement

2. Connect the equipment as shown in Figure 4-1, then proceed as follows:

- a) Set the oscilloscope to DC, Time/cm to Ext. X, and gain to 10mv/cm.
- b) Set the sweep generator to the video sweep mode with the start frequency at 150 kHz and the sweep width to 150 MHz.
- c) Disconnect the 3100LA from the set-up and connect the sweep/generator RF output directly to the 30 dB attenuator.
- d) Adjust the output level of the sweep/generator for full vertical deflection on the oscilloscope face.
- e) Calibrate the scope face to show 3 dB in 1 dB steps by attenuating the sweep/generator in 1 dB steps.
- f) Return sweep/generator output level to full deflection. Rotate the

The material contained in this document is the property of Electronics & Innovation Ltd., it is subject to change without notice.

- step attenuator (CCW) so that the output is reduced by 50 dB.
- g) Reconnect the 3100LA into the test set-up of Figure 4-1.
- h) Place the 3100LA power switch to the "ON" position.
- i) Observe the gain versus frequency sweep on the oscilloscope.
  - The average gain should be greater 50 dB
  - The gain variation should be within the 3 dB as shown on the oscilloscope.

#### 4.4.2 Measurement of Harmonics

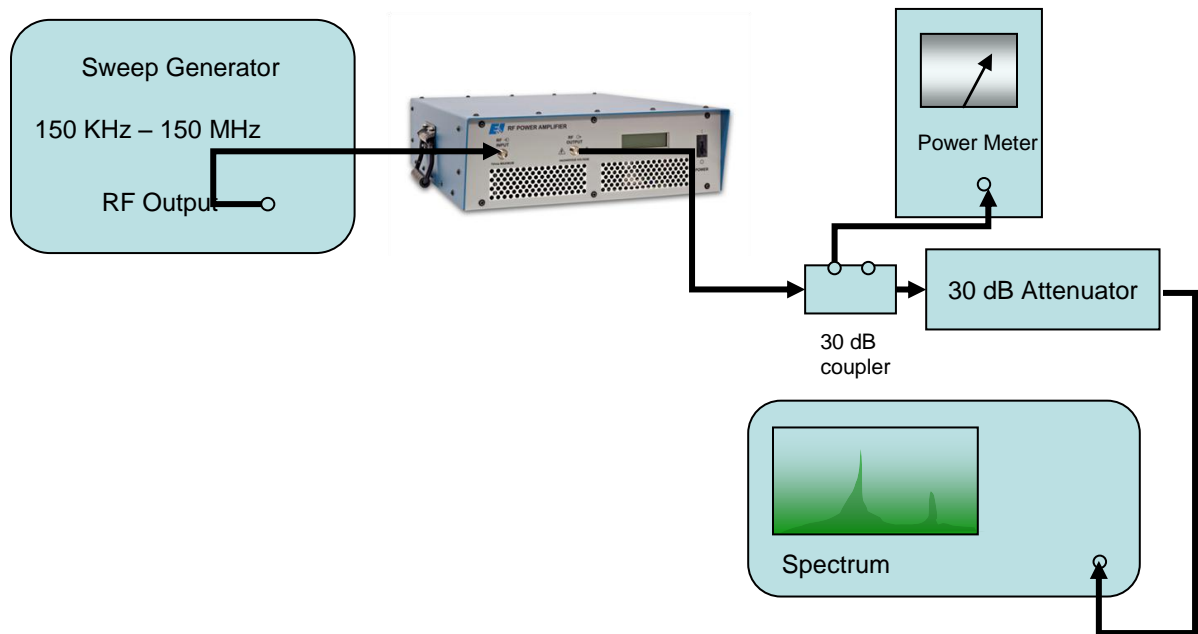

Figure 4-2.

- 1.) Equipment Required:
  - a) Sweep/Signal Generator
  - b) Calorimetric Power Meter HP435B
  - c) Spectrum Analyzer.
  - d) Attenuator (30dB)
  - e) Coupler (30 dB)
- 2.) Connect the Equipment as shown in Figure 4-2, then proceed as follows:
  - a) Adjust the signal generator to a CW center frequency of 250 kHz, for an indicated output of 100 watts on the power meter.
  - b) Using the spectrum analyzer, check that the level of the carrier harmonics is less than -25 dB with respect to the carrier while manually scanning the frequency band of 250 KHz to 150 MHz. An indicated power output of 100W should be maintained during this operation.

The material contained in this document is the property of Electronics & Innovation Ltd., it is subject to change without notice.

## 4.5 PACKAGING FOR RESHIPMENT

In the event of the equipment being returned for servicing it should be packed in the original shipping carton and packing material. If this is not available, wrap the instrument in heavy paper or plastic and place in a rigid outer box of wood, fiberboard or very strong corrugated cardboard. Use ample soft packing to prevent movement. Provide additional support for projecting parts to relieve these of unnecessary shock. Close the carton securely and seal with durable tape. Mark the shipping container FRAGILE to ensure careful handling.

---

### **Chapter 5 Safety:**

Do not attempt to operate this unit with the cover removed. High AC and DC voltages are present. The cover prevents against electrical shock due to AC line voltages, high DC and RF fields. Further the cover provides part of the cooling system design. Components, specifically on the RF driver board are prone to over-heat and eventual failure if the unit is operated without the cover in place.

Ensure that the load is connected to the output prior to connecting the RF input to the unit. This will prevent high voltages being present and exposed at the output connector.

Only use the AC cord provided or equivalent.

Ensure that the mains outlet is properly grounded.

The material contained in this document is the property of Electronics & Innovation Ltd., it is subject to change without notice.